

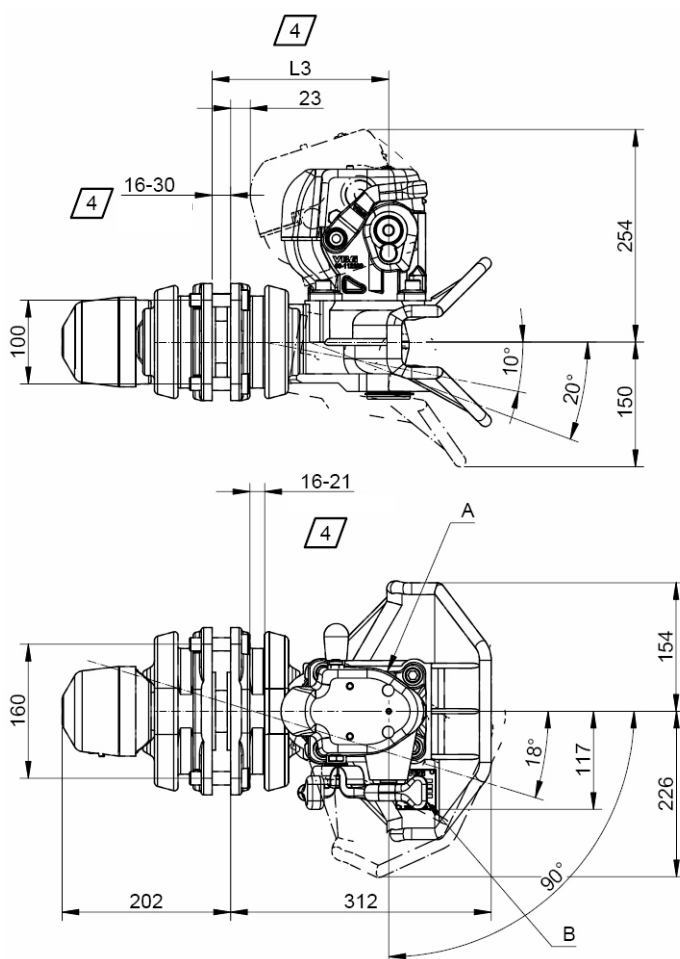

The comfort coupling for trailers with articulated drawbar and 50 mm drawbar eye. The small number of component parts and robust design ensure low running costs and reliable operation. The well-proven attachment package means first-rate driving comfort, while the automatically functioning lock pin also simplifies handling.

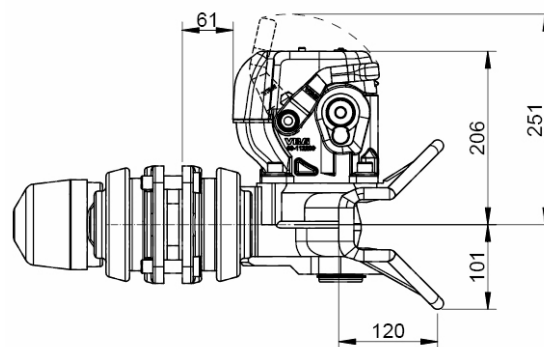

With a rotation of up to 40° the coupling returns to its normal position when the load is released. In the event of an accident, the coupling can rotate 360° in its attachment. General tolerance +/- 10 mm.



4: The distance to the coupling centre "L3" varies depending on the compression of the rubber element as well as the drawbeam thickness (see table).

Drawbeam thickness	Pretension	
	16	21
16	204	208
20	208	212
22	210	214
28	216	220
30	218	222

SPECIFICATIONS

Coupling VBG 8500

Performance values

Hole pattern, drawbeam

Intended for eye

Part no. 08-009000

D 190 kN

160 x 100 mm

50 mm as per

ISO 1102:2001/

DIN 74053/SMS996

Dead weight

EU coupling class

EU approval no.

42 kg

C50-X

e4*94/20*0062

E4*55R-010067