

# VBG 5190D



The comfort coupling for trailers with articulated drawbar and 50 mm drawbar eye.

VBG 5190D has increased bolt/bushing supporting surfaces and is ideal for use in combination with high total weights and demanding environments. The well-proven attachment package means first-rate driving comfort, while the automatically functioning lock pin also simplifies handling.

With a rotation of up to 40° the coupling returns to its normal position when the load is released. In the event of an accident, the coupling can rotate 360° in its attachment.

General tolerance +/- 10 mm.

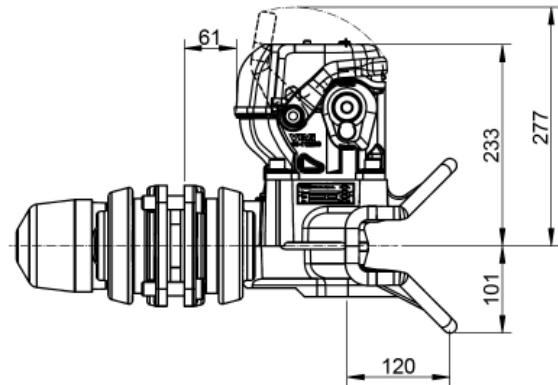
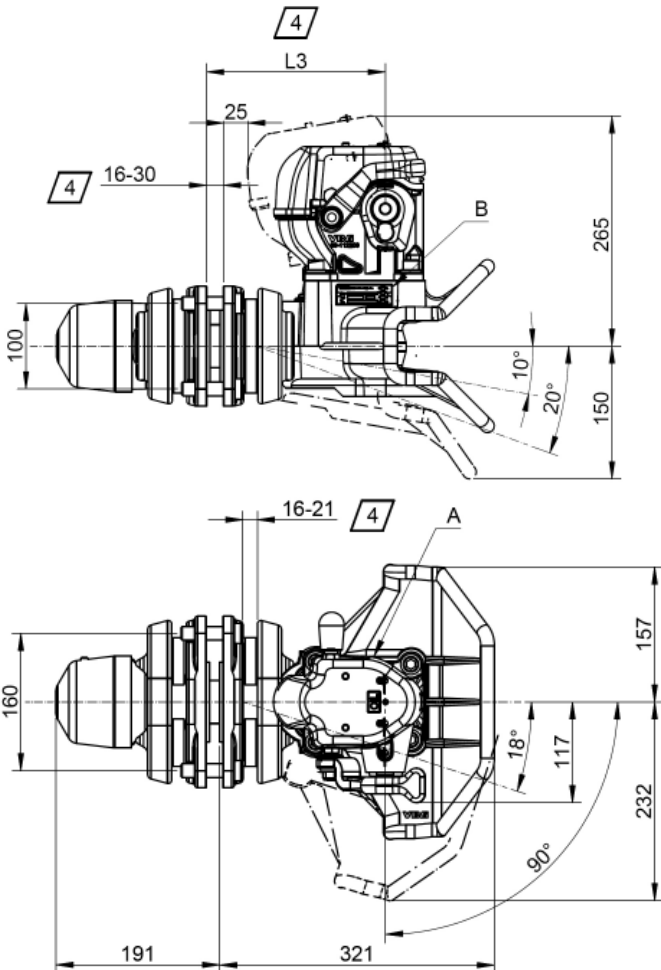

4: The distance to the coupling centre "L3" varies depending on the compression of the rubber element as well as the drawbeam thickness (see table).

Drawbeam thickness	Pretension	
	16	21
16	204	208
20	208	212
22	210	214
28	216	220
30	218	222

## SPECIFICATIONS

**Coupling VBG 5190D**

**Performance values**

Hole pattern, drawbeam  
Intended for eye

**Part no. 09-127500**

D 190 kN

160 x 100 mm

50 mm in accordance  
with ISO 1102:2001/  
DIN 74053/SMS996

Dead weight

44 kg

EU approval no.

e11\*94/20\*6775

E11\*55R-016775

EU coupling class

C50-X

Angular displacement for eye

Horizontally

± 90°

Vertically

± 25°

Axially

± 40°